

Saddlebag Support Bars – Indian Scout

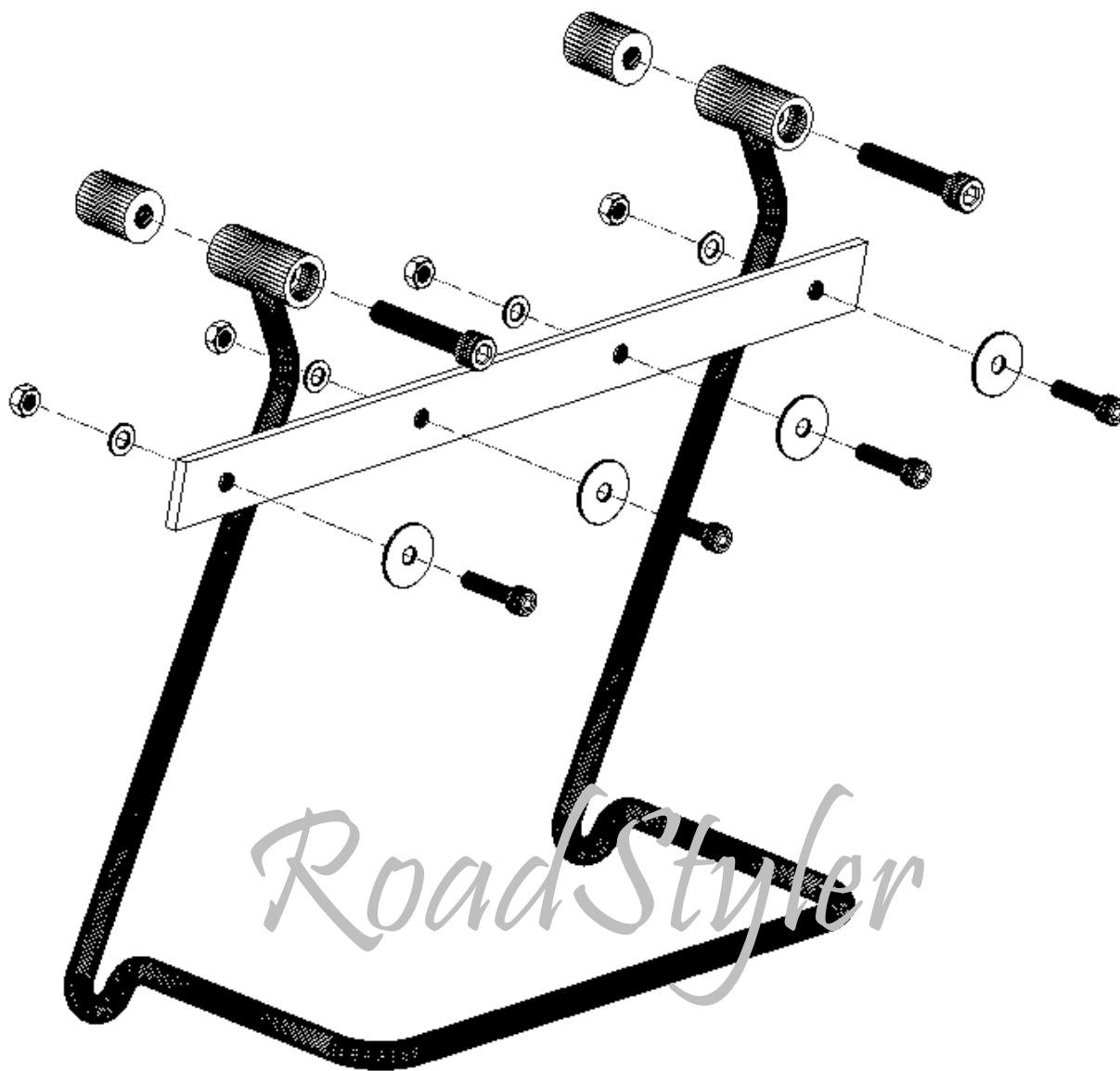

General information and comments:

1. Do not tighten the screws too tight.
2. Tighten all main 2 screws at the end - after assembling the entire structure on a motorcycle.
3. Always check the screw length and pitch - compare to the original. The final length of the screw depends on the installed components on the bike.
4. **WARNING-1: After installation check whether support bar (or saddlebag) will not hit the overhang elements of the motorcycle (eg belt or cardan shaft) while driving!**
5. **WARNING-2: sleeves in the racks are not welded perpendicular to the motorcycle, so keep the distance of 16mm (sleeves in the set) from the surface of the fender to the support. If, for example, the backrest of another manufacturer is mounted, there may be a fitting problem.**